

1U 815/813M/116 chassis

3(3)(b):

Data storage devices

- Type of operation: Push the release button on carrier. Swing the handle fully. Grasp the handle and pull the driver carrier out of its bay.
- Type and number of fastenings to be unlocked: 1 latch and 6 Phillips screws.
- Tools required: Screwdriver with PH2 bit.

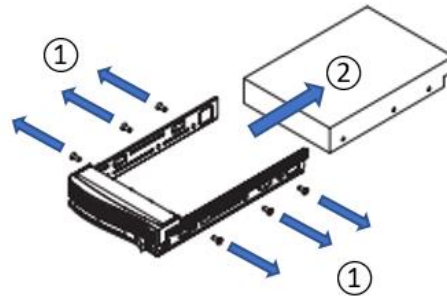
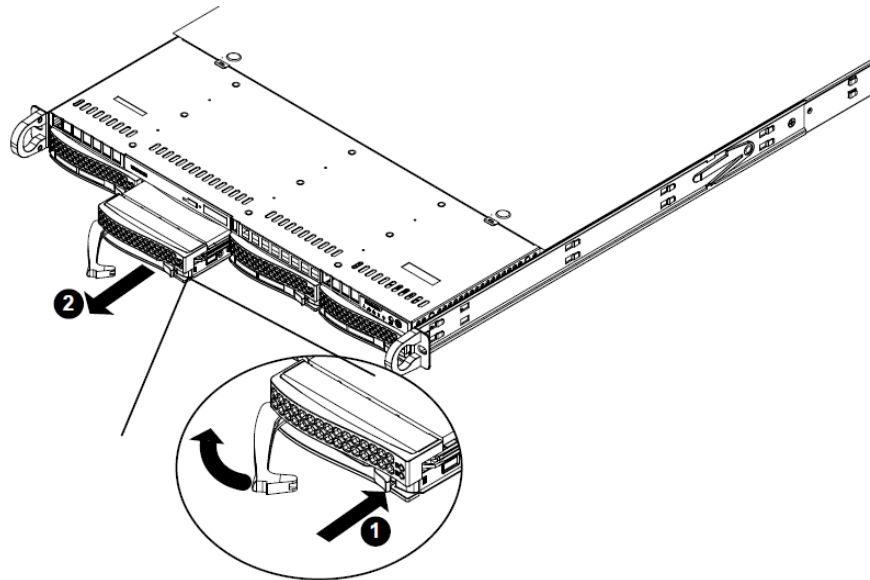

Memory

- Type of operation: Press both release tabs on the ends of DIMM module to unlock. Once DIMM module is loosened, remove it from the memory slot.
- Type and number of fastenings to be unlocked: 2 latches per DIMM.
- Tools required: None.

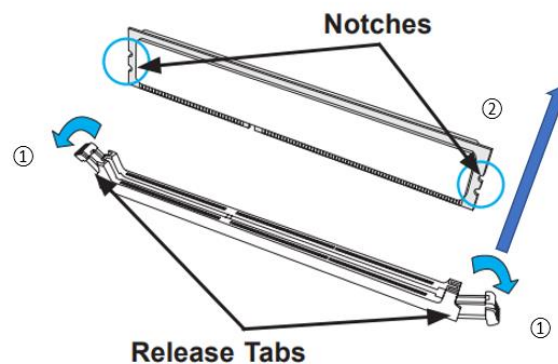

Please note: All the graphs in this disassembly instruction are for demonstration only. Components in the graphs may not match exactly with the actual components.

Processor (CPU)

➤ **Socket LGA-3647:**

- Type of operation: Remove the screws in the sequence of 4,3,2,1. After removing the screws, lift the Processor Heatsink Module off the CPU socket. Un-snap Corner A,B then C,D of the latch. Push the latch out from the top.
- Type and number of fastenings to be unlocked: 4 T30 Torx screws.
- Tools required: Screwdriver with T30 Torx bit.

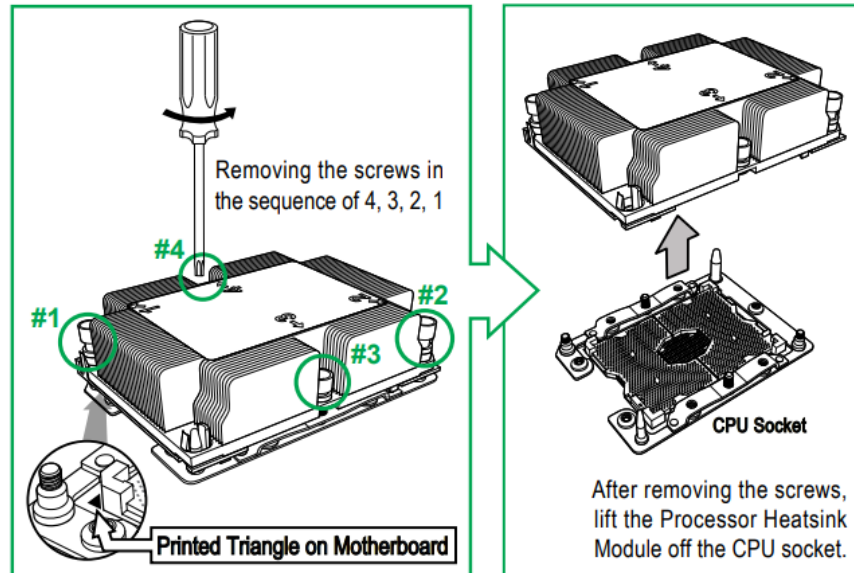

Un-snap Corner A,B then C,D of the latch. Push the latch out from the bottom.

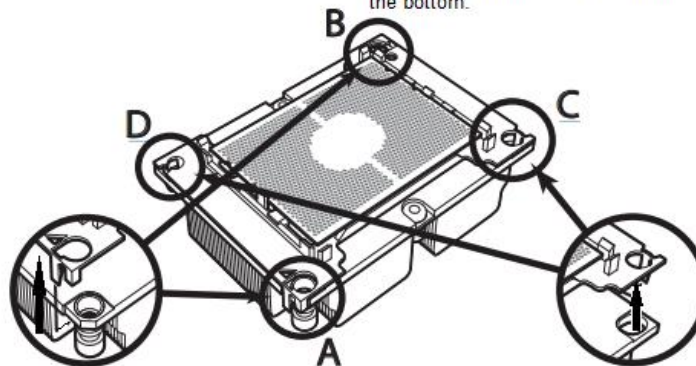

Please note: All the graphs in this disassembly instruction are for demonstration only. Components in the graphs may not match exactly with the actual components.

➤ **Socket LGA-1151:**

- Type of operation: Remove the screws in the sequence of 4,3,2,1. After removing the screws, lift the Processor Heatsink off the CPU socket. Press the load lever to release the load plate from its locker position. Gently lift the load lever to open load plate and carefully remove the CPU from its socket.
- Type and number of fastenings to be unlocked: 4 Phillips screws on heatsink.
- Tools required: Screwdriver with Phillips bit.

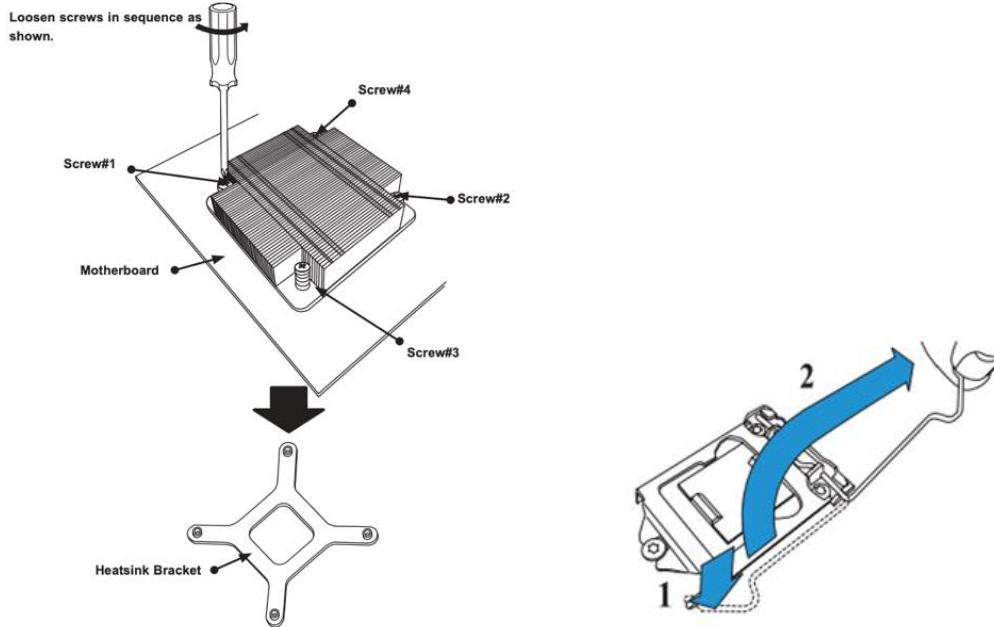

Motherboard

- Type of operation: Remove Phillips screws. Lift the motherboard from its base.
- Type and number of fastenings to be unlocked: Phillips screws.
- Tools required: Screwdriver with PH2 bit.

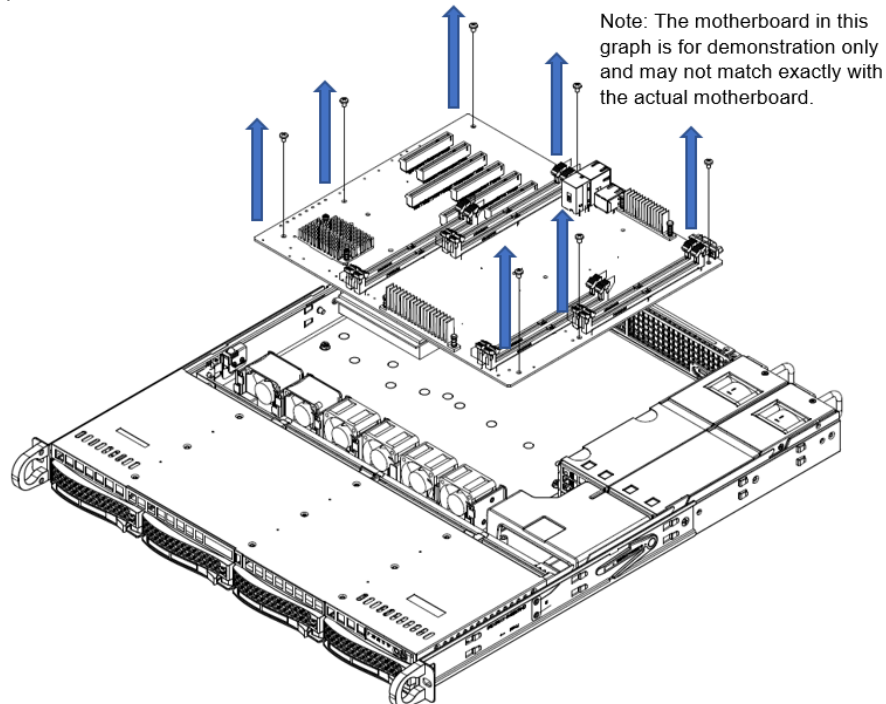

Please note: All the graphs in this disassembly instruction are for demonstration only. Components in the graphs may not match exactly with the actual components.

Expansion card/graphic card

- Type of operation: (Remove Phillips screws). Then open the rear window latch. Carefully remove expansion card from riser card slot. Finally lift expansion up and away from the system.
- Type and number of fastenings to be unlocked: Phillips screw.
- Tools required: Screwdriver with PH2

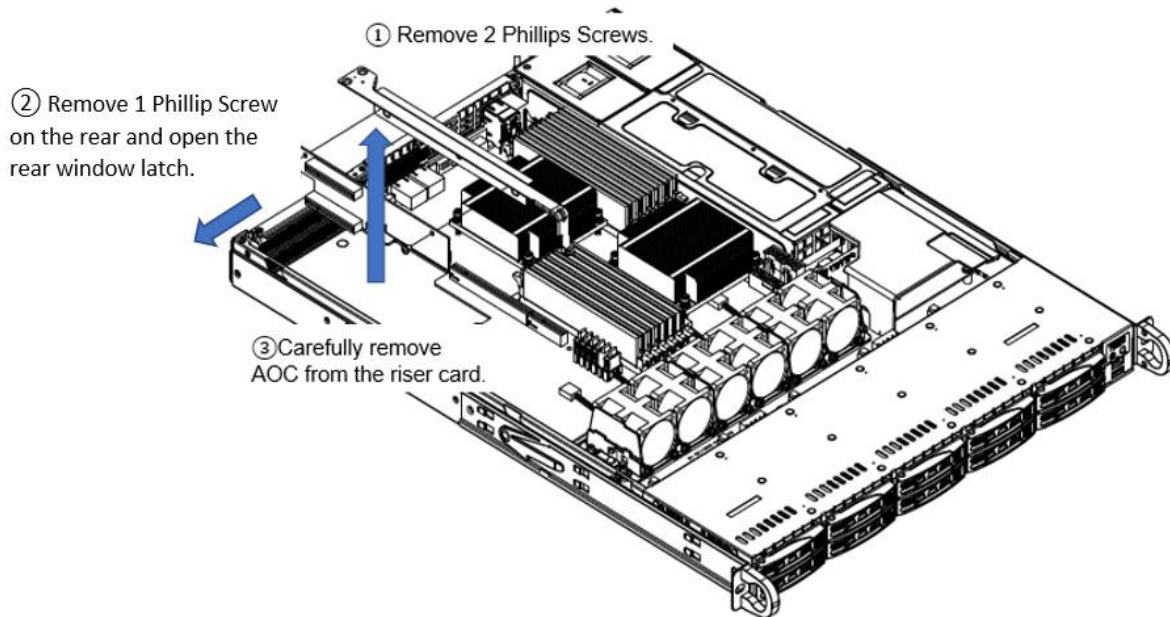

PSU

- Type of operation: Unplug the power cord from PSU. Push the release tab on the back of PSU to the side and pull the module straight out.
- Type and number of fastenings to be unlocked: 1 latch per PSU.
- Tools required: None.

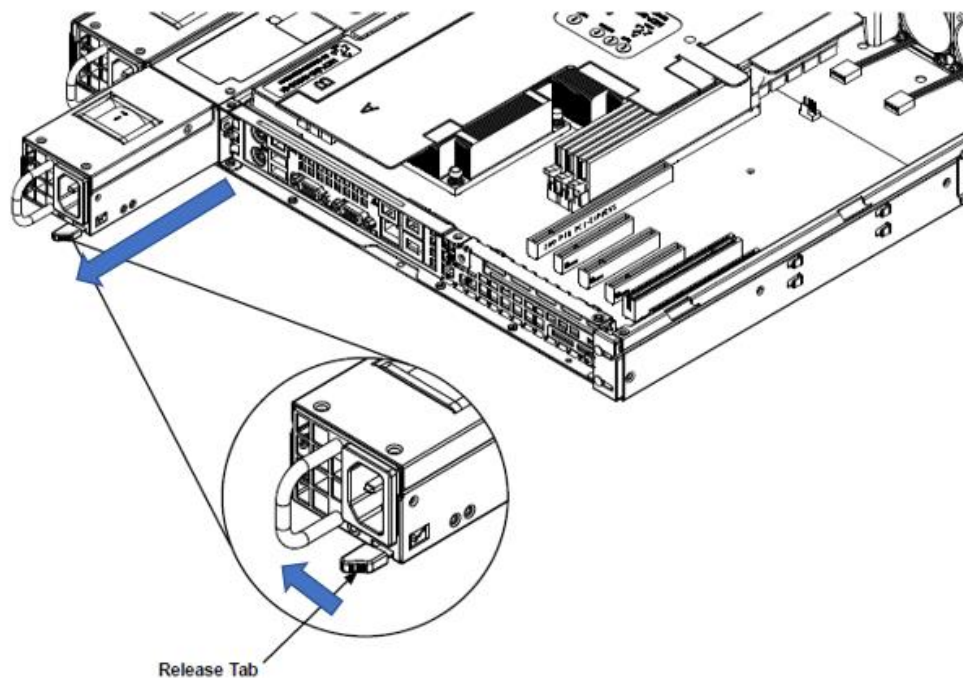

Please note: All the graphs in this disassembly instruction are for demonstration only. Components in the graphs may not match exactly with the actual components.

Chassis

- Type of operation: Push down on the two buttons simultaneously and hold. Keep applying pressure on the buttons and push away the top cover. (815/813M); Loose the knob at the rear of system. Push down onto chassis cover and away. (116)
- Type and number of fastenings to be unlocked: Up to 2 latches.
- Tools required: None.

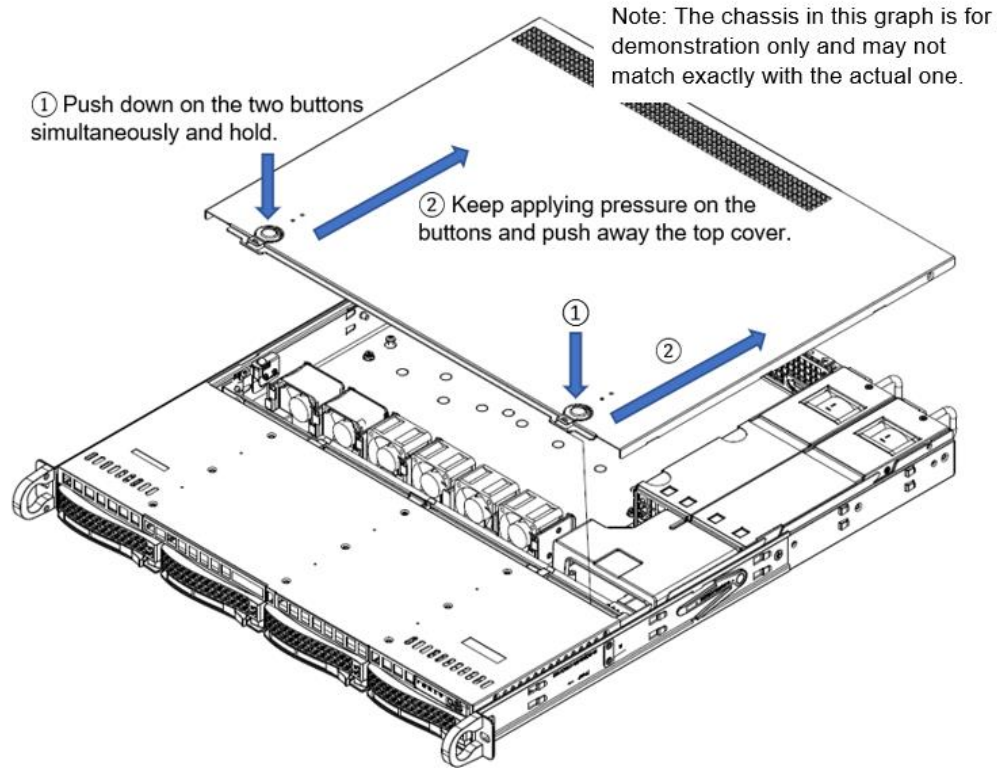

Batteries

- Type of operation: Push aside the small clamp that covers the edge of the battery. When the battery is released, lift it out of the holder.
- Type and number of fastenings to be unlocked: 1 latch.
- Tools required: None.

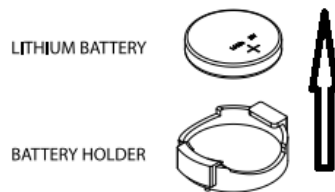

Please note: All the graphs in this disassembly instruction are for demonstration only. Components in the graphs may not match exactly with the actual components.

Riser Card

- Type of operation: Remove the screw and lift the riser card up from motherboard expansion slot.
- Type and number of fastenings to be unlocked: Phillips screws.
- Tools required: Screwdriver with PH2 bit.

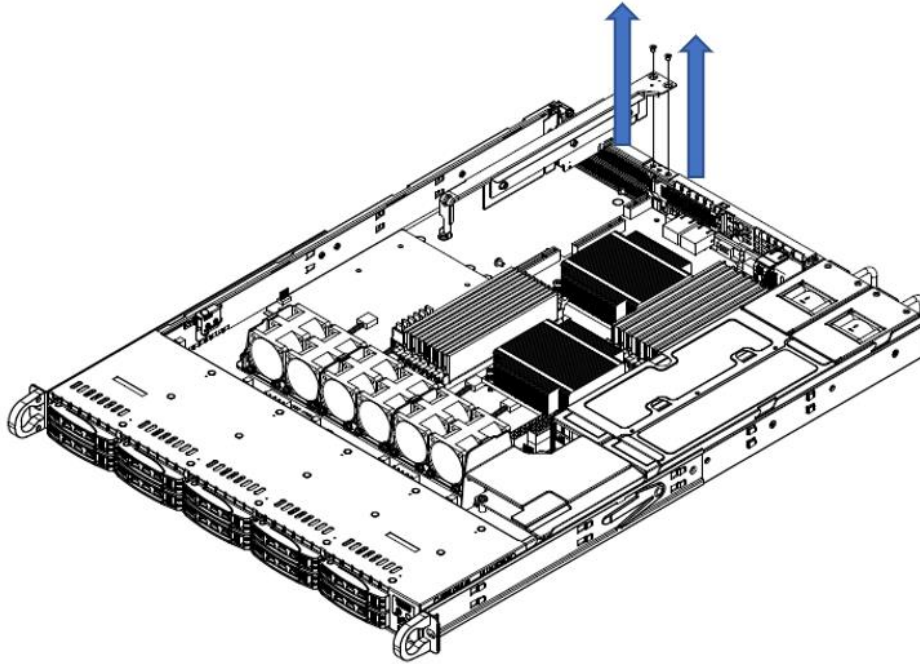

Fans

- Type of operation: Disconnect fan's wiring from fan header on the motherboard. Then remove the fan from fan tray.
- Type and number of fastenings to be unlocked: 1 fan header per fan.
- Tools required: none.

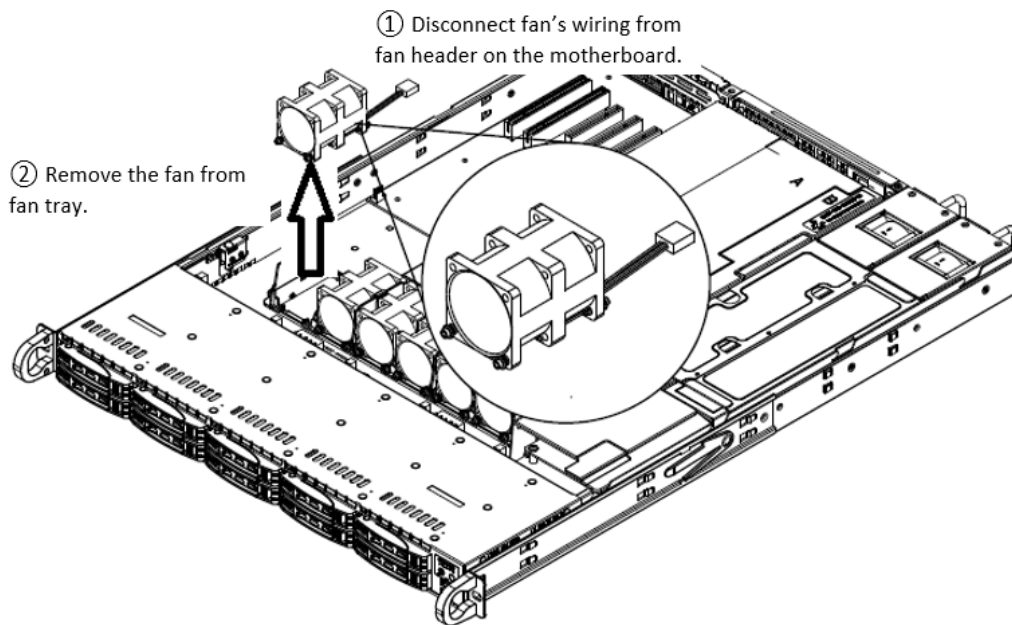

Please note: All the graphs in this disassembly instruction are for demonstration only. Components in the graphs may not match exactly with the actual components.

Power Distribution Board (PDB)

- Type of operation: Remove 4 Phillips screws. Lift the PDB from its base.
- Type and number of fastenings to be unlocked: 4 Phillips screws.
- Tools required: Screwdriver with PH2 bit.

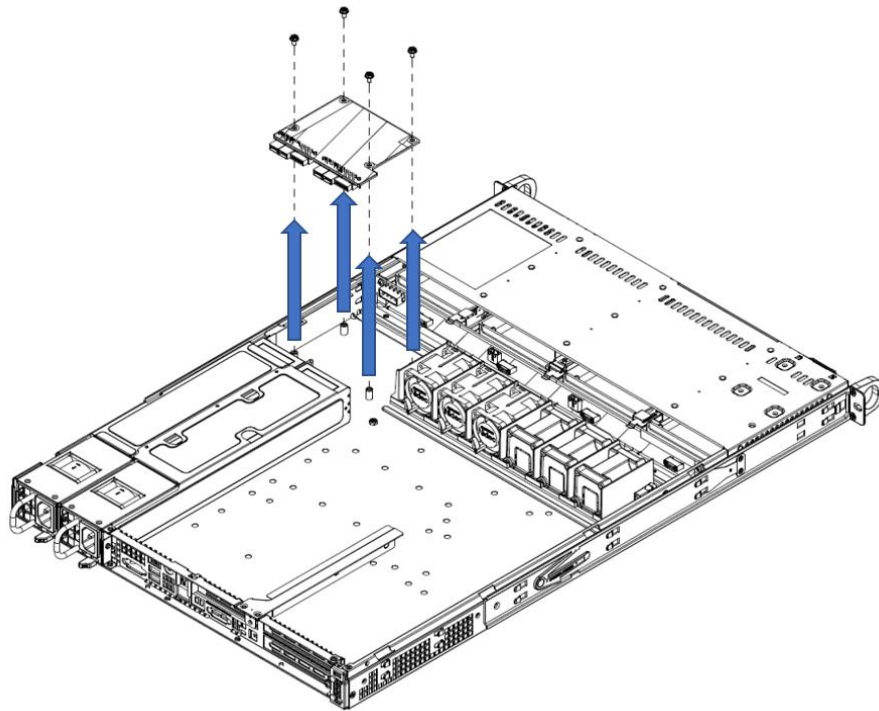

Backpanel

- Type of operation: Remove 2 Phillips screws. Swing the bottom part of the backpanel out from its slot first then slide the backpanel away from its top metal clamps.
- Type and number of fastenings to be unlocked: 2 Phillips screws.
- Tools required: Screwdriver with PH2 bit.

